

TOP VIEW

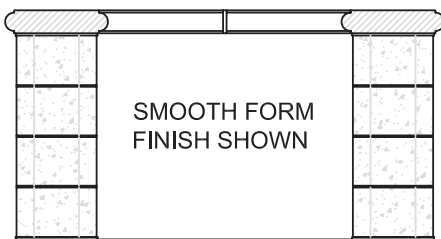

SIDE VIEW

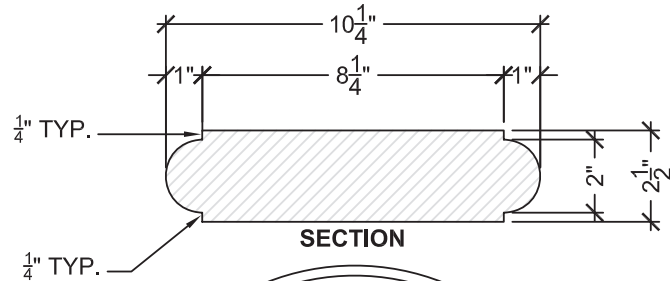

SECTION

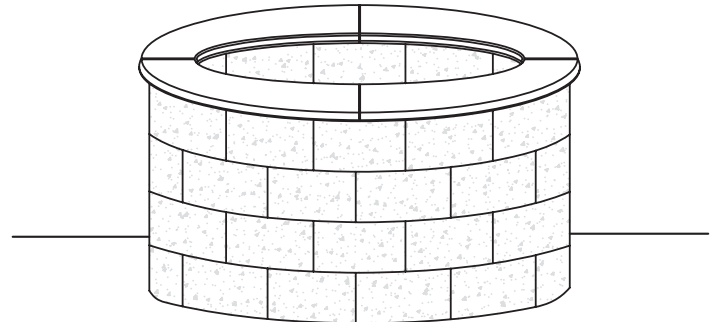
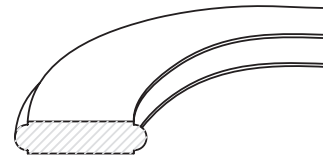
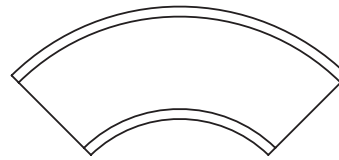

NOTES:

1. PRECAST UNITS ARE INDIVIDUALLY HAND CAST. LENGTHS ARE APPROXIMATE. SOME VARIATIONS ARE EXPECTED.
2. INSTALLATION TO BE COMPLETED IN ACCORDANCE WITH GENERALLY ACCEPTED MASONRY PRACTICES.
3. SMOOTH FINISH ON TOP & NOSE. SANDBLAST FINISH AVAILABLE.
4. PRECAST UNITS MAY BE CUT TO FIT FIELD CONDITIONS.
5. WE DO NOT RECOMMEND THE USE OF OUR CONCRETE PRODUCTS IN ENVIRONMENTS THAT WILL HEAT THE CONCRETE TO MORE THAN 200 DEGRESS. DIRECT EXPOSURE TO A FIRE'S FLAME FOR AN EXTENDED PERIOD OF TIME WILL DAMAGE THE CONCRETE. INSTALLATIONS SUBJECTING STEPSTONE'S PRECAST PIECES TO EXCESSIVE HEAT WILL VOID THE MANUFACTURER'S WARRANTY AND STEPSTONE, INC WILL NOT REPLACE ANY DAMAGED PRODUCT.

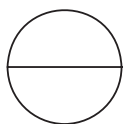

CLASSIC FIRE PIT CAP

SCALE: N.T.S.