

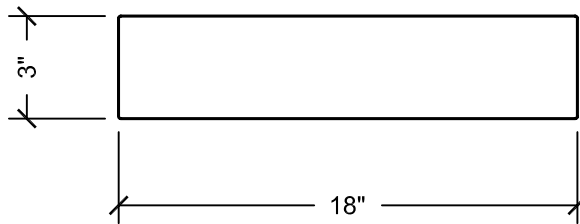

TOP VIEW

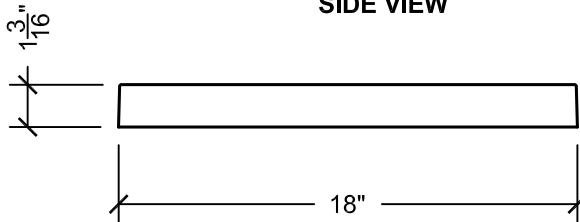

SIDE VIEW



SIDE VIEW

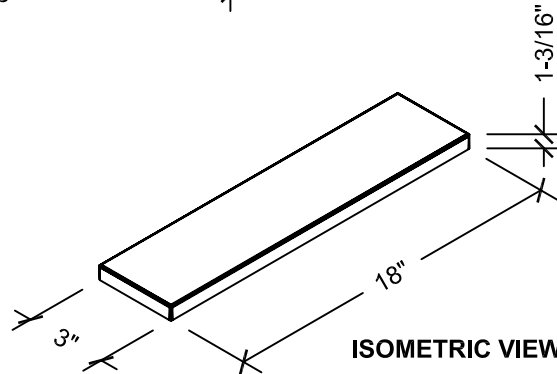
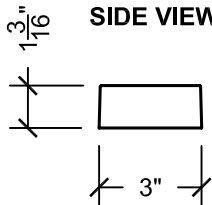

NOTES:

1. NARROW MODULAR TILE SHOWN ABOVE SHALL BE 1-3/16" THICK AS MANUFACTURED BY STEPSTONE, INC. PAVERS SHALL HAVE A MINIMUM COMPRESSIVE STRENGTH OF 5,000 P.S.I.
2. THESE PAVERS MUST BE MORTAR SET ONLY.
3. SANDBLAST FINISH - LIGHT, MEDIUM OR HEAVY.
4. NARROW MODULAR TILES ARE AVAILABLE IN TWELVE (12) STANDARD COLORS. CUSTOM COLORS AND SIZES MAY BE AVAILABLE UPON REQUEST.
5. ALL DIMENSIONS ARE NOMINAL. ALL SIDES HAVE DRAFT. SEE SPECIFICATIONS FOR TOLERANCES.

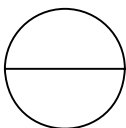

NARROW MODULAR TILE, 18" x 3" x 1-3/16"

SCALE: N.T.S.

Visit us at our website www.stepstoneinc.com

